



Makina Takım Endüstrisi A.Ş.



Makina Takım Endüstrisi A.Ş.



HAVŞA  
FREZELER

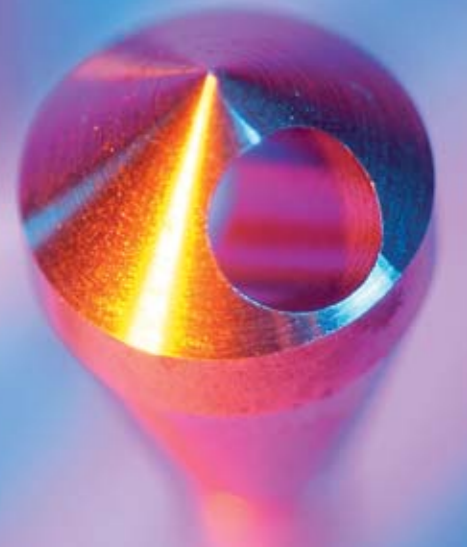



### 3 AĞIZLI HAVŞA FREZE



<b>Malzeme</b>	Yüksek hız çeliği (HSS)
<b>Uç Açısı</b>	60°-90°
<b>Kullanım Alanları ve Özelliği</b>	DIN 335/C sağ kesicili, demir ve demir dışı metaller ile sert veya yumuşak plastik malzemelerin her türlü delme havşalama işlemlerinde kullanılır.

Ürün kodu	Havşa Çapı "d1" (mm)	Şaft Çapı "d2" (mm.)	Toplam Boy L (mm.)
B00313120630	6.3	5	45
B00313120830	8.3	6	50
B00313121040	10.4	6	50
B00313121240	12.4	8	56
B00313121650	16.5	10	60
B00313122050	20.5	10	63
B00313122500	25	10	67
B00313123150	31.5	12	71

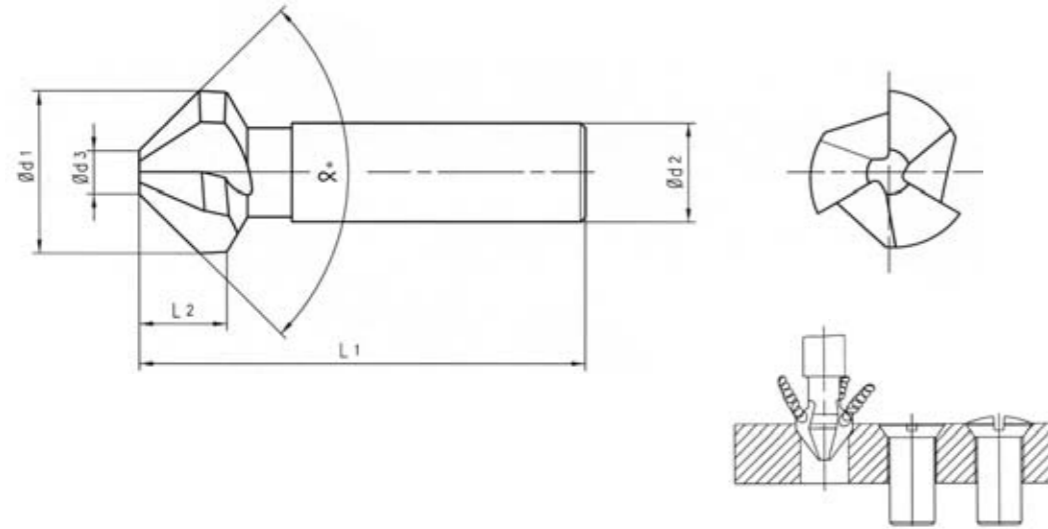

### DELİKLİ HAVŞA FREZE



<b>Malzeme</b>	Kobalt alaşımlı Yüksek Hız Çeliği (HSS-E)
<b>Uç Açısı</b>	90°
<b>Kullanım Alanları ve Özelliği</b>	Gövdedeki delik talaş tahliyesini kolaylaştırır. İşlenen malzemede pürüzsüz yüzey sağlar. Demir ve demir dışı metaller ile sert veya yumuşak plastik malzemelerde kullanımı uygundur.

Ürün kodu	Çalışma Aralığı (mm)	Çap "d1" (mm)	Şaft Çapı "d2" (mm.)	Toplam Boy L (mm.)
B00369990068	2-5	10	6	45
B00369990069	5-10	14	8	48
B00369990070	10-15	21	10	65
B00369990071	15-20	28	12	85
B00369990072	20-25	35	12.7	102

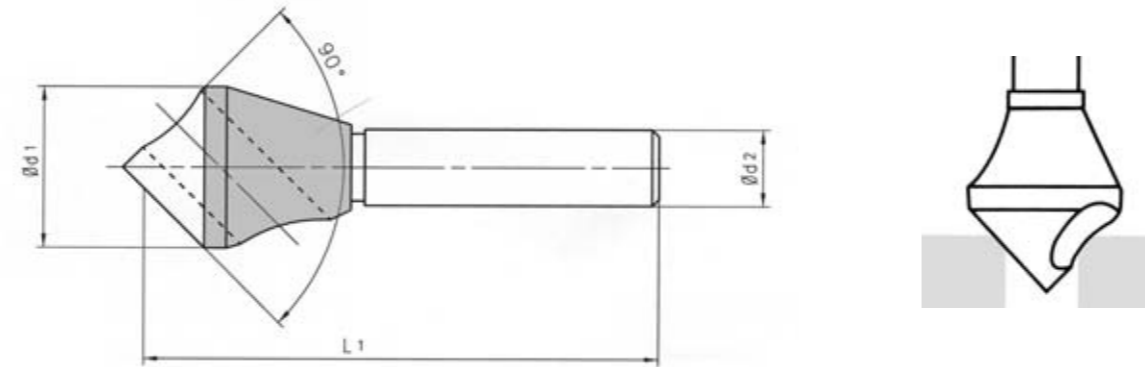

### ALTI KÖŞE ŞAFTLI HAVŞA FREZE



<b>Malzeme</b>	Yüksek hız çeliği (HSS)
<b>Uç Açısı</b>	60°-90°
<b>Kullanım Alanları ve Özelliği</b>	Levha ve benzeri malzemeleri pürüzsüz havşalamak için el breyizleri ve makinalarda kullanılır.

Ürün kodu	Havşa Çapı "d1" (mm)	Şaft Çapı "d2" (mm.)	Toplam Boy L (mm.)
B00319990564	6.3	1/4-6 Köşe	31
B00319990556	8.3	1/4-6 Köşe	31
B00319990565	10.4	1/4-6 Köşe	34
B00319990557	12.4	1/4-6 Köşe	35
B00319990558	16.4	1/4-6 Köşe	40
B00319990566	20.4	1/4-6 Köşe	41

